

USG Powerscape Fiberock® Interior Linings Installation Guide

Health and Safety

Under normal conditions of use, USG Powerscape® interior linings present no known health hazard.

- Knives used for scoring and snapping need to be sharp to operate effectively. Extreme care needs to be taken when using any cutting implements.
- Approved dust masks and eye protection must be worn for all cutting of linings and sanding of stopping compounds.
- Do not dispose of waste materials or compounds into any drainage system.

Site Conditions

It is important to consider the impact of damp and cold site conditions on the finish quality once the building has been occupied and reaches equilibrium.

A minimum temperature (interior) of 10°C must be maintained during the lining fixing process and a controlled heat of between 13-20°C must be maintained for 24 hours before, during and after the joint stopping operations. With concrete slab construction provide sufficient ventilation to minimise the build up of internal humidity which will increase the risk of sagging of linings as well as delaying the project due to prolonged drying/curing of joint compounds.

Failure to observe these requirements may result in lining and framing surface defects.

Stacking, Storage and Handling

- Linings must be neatly stacked to avoid sheet distortion, damage or moisture ingress. This can be achieved by stacking on a clean flat surface not susceptible to moisture. Linings stacked flat on a concrete floor must be separated from the floor surface by a moisture barrier such as a polythene sheet or placed on bearers (min 75 x 50).
- Consider floor loadings, as USG Powerscape® interior linings weigh approximately 950 kg/m³. Stacks of board should be limited to 12 sheets (13mm) or 10 sheets (16mm) on suspended floors to minimise the risk of structural damage through point loading. Prevent undue sagging or damage to edges, ends or surfaces during handling or storage. Vertical edge stacking is not recommended.
- Lift sheets from the stack rather than dragging them. This reduces the risk of damage to the face of the board. Carry sheets on edge. This is easier than carrying them on the flat and sheets are less likely to crack or break.

Protection from weather

USG Powerscape® interior linings must be kept dry preferably by being stored inside a building and under cover. Where it is necessary to store USG Powerscape® interior linings outside, it must be stacked off the ground and be fully protected from the weather.

Framing

USG Powerscape® interior linings are a relatively stable material when subjected to a normal range of temperatures and humidity. The ultimate performance of the lining is heavily influenced by the quality of the framing to which it is attached. Both steel and timber framing is recommended for the use of USG Powerscape® interior linings. Any framing used to attach USG Powerscape® interior linings needs to be flat. Common causes of not achieving a flat surface are:

- Bent studs
- Protruding noggs /dwangs
- Steel angle braces not set flush with the surface of the framing
- Skew nails not driven home
- Inconsistent machining of timber frame especially at the stud lintel connection
- Poorly assembled timber or steel framing
- Nail plates or hold down ties not set flush with surface of the framing
- Excess insulation forced into the cavity
- Pipes and wiring not correctly set back in the cavity
- Screws in steel framing not countersunk flush.

If any of these conditions exist, they must be rectified prior to the installation of any board. AS/NZS 2589 for a level 4 finish the maximum deviation of 90 % of the framing from 1.8 m straight edge should not exceed 4 mm. It is recommended that the maximum deviation of all framing from 1.8 m straight edge should not exceed 3 mm.

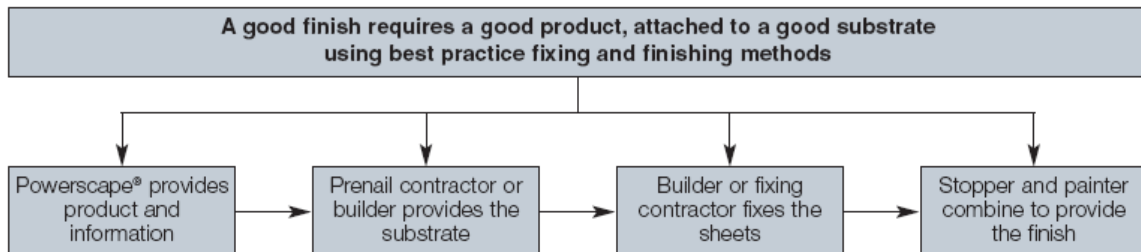

Timber Shrinkage Chart

For a moisture content less than 28 %, timber can shrink up to 1 % for every 4 % of moisture lost. Timber tends to stabilize at around 10 - 12 %. USG Powerscape® interior linings can generally handle the minimal amount of shrinkage that can occur for moisture movements from 12 to 16%. Fixing USG Powerscape® interior linings to timber with moisture content in excess of 16 % will increase the risk of surface defects such as peaking joints and popped fasteners.

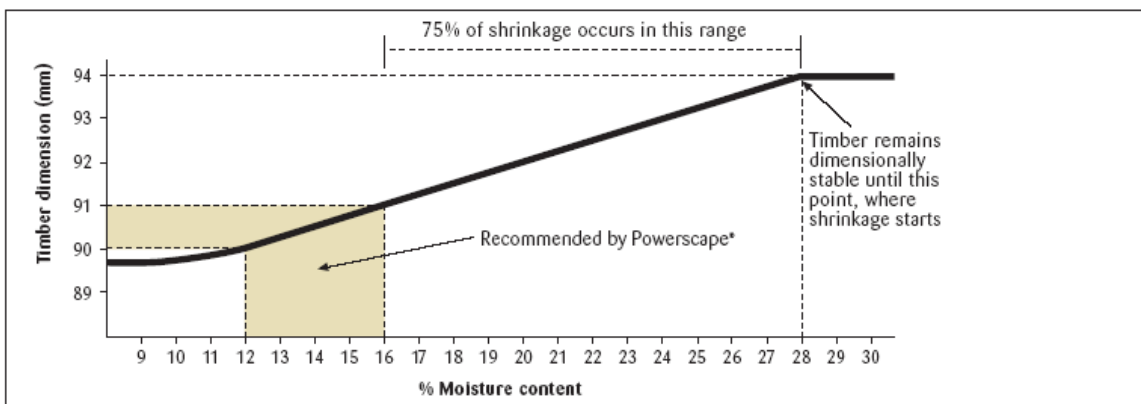

Cutting and attaching linings

Cut ends, edges, and/or scribe and make cut-outs within the face of the linings in a workmanlike manner. USG Powerscape® interior linings can be cut to required size in various ways, including score and snap, sawing and shearing as detailed below.

'Dust-Free' Sites

- Score and snap. To score and snap USG Powerscape® interior lining multiple scores should be made in both the top and bottom surfaces of the sheet with a sharp knife. For USG Powerscape® Aqua-Tough VHI ensure the bottom scores cut right through the mesh. The sheet can then be simply snapped.
- Shearing. A Snapper Shear® tool designed especially for Fiberock® technology products such as USG Powerscape® interior lining is available, providing another cutting option.



Other Sites

- Sawing. In markets where contractors have been using USG Powerscape® interior lining type products for some time they favour either score and snap or the use of a low RPM thin blade saw, such as the DeWalt® Heavy Duty 165mm cordless 18v circular saw. This type of saw has the advantage of being cordless, and the thin blade and low speed minimise dust generation. A jigsaw with pendulum action and coarse blade is also a good choice, especially for non linear cuts. Other power saws can also be used with dust collection devices. Standard wood working handsaws also work very effectively. Any edge roughness can be removed with a wood working plane or rasp. The Microplane® Fibrelock® rasp blade is designed to minimise clogging as is particularly effective. Holes for pipes, fixtures, and other small openings can be drilled by hand or powered drill, or cut with a hand or powered jigsaw, or a drywall router equipped with a 6mm carbide bit. When using a router, linings should be held away from the wall to avoid damage to utility boxes.



Walls

Sheet Layout

For 2400 mm high applications install two 3000mm linings horizontally. For 2700mm high applications either install 3000 mm sheets (cut to length) vertically or install one 1200 mm wide sheet horizontally, followed by half sheets (1500 mm long) vertically. For 3000 mm walls install sheets vertically, or two sheets plus a half sheet horizontally.

Position all ends and edges of linings over framing members, except when joints are at right angles to framing members as in horizontal fixing or when end joints are back-blocked. End joints should be staggered in successive courses. End joints on opposite sides of a partition should be placed on different studs.

Install linings a minimum of 5mm above the floor. The 5mm gap between the interior lining and the floor can be left empty except for fire or sound rated walls where the gap must be sealed with a fire and/or acoustic rated sealant aligned to the wall rating.

Fixing

Attach linings to framing supports with mains power, or high voltage fully charged cordless screw driver. Ensure fastener heads are driven slightly below surface (1.0mm approx.) of linings in a uniform dimple. For fire rated systems use fasteners as shown for the particular system. Space fasteners not less than 12mm from edges and ends of linings. Drive fasteners in the middle of linings first, working toward ends and edges. Hold lining in firm contact with framing while driving fasteners. For non-fire-rated and non-bracing rated partition designs, refer to the table below for fastener spacing and minimum type. For fire-rated partition and bracing designs, refer to the specific design for proper fastener spacing. (Note: specific fire rated details are on back page)

Fasteners and Spacing

Frame Spacing Lining Thickness	Fastener Spacing Nails and Staples	Fastener Spacing Screws
600 mm 400 mm	200 mm 200 mm	300 mm 400 mm
For 13mm Fiberock	25mm x 2.8 nail or 16g x 12.7 x 38mm staple	25mm x 6g drywall screw
For 16mm Fiberock	30mm x 2.8 nail	32mm x 6g drywall screw
For 2 x layers of Fiberock	50mm x 2.8 nail	50mm x 8g drywall screw

Install trim at all internal and external angles formed by the intersection of either lining surface or other surfaces. Apply corner bead to all vertical or horizontal external corners in accordance with manufacturer's directions.

Fastening USG Powerscape® Interior Linings to metal framing

As the face of a steel stud can deflect initially, the correct sequence of attaching the lining is important. The first sheet is attached to the open side of the stud which will cause minor deflection but will pull back tight against the sheet when the screw is fully tightened.

When the second sheet is fixed there will be minimal deflection as the open flange is now supported by the previous sheet. Support the stud to avoid twisting.

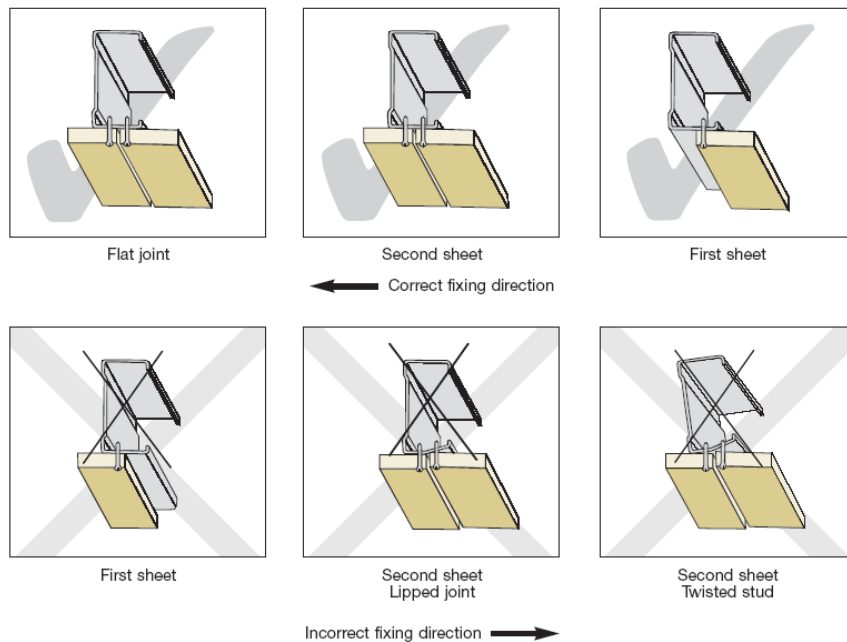

Joint placement around openings

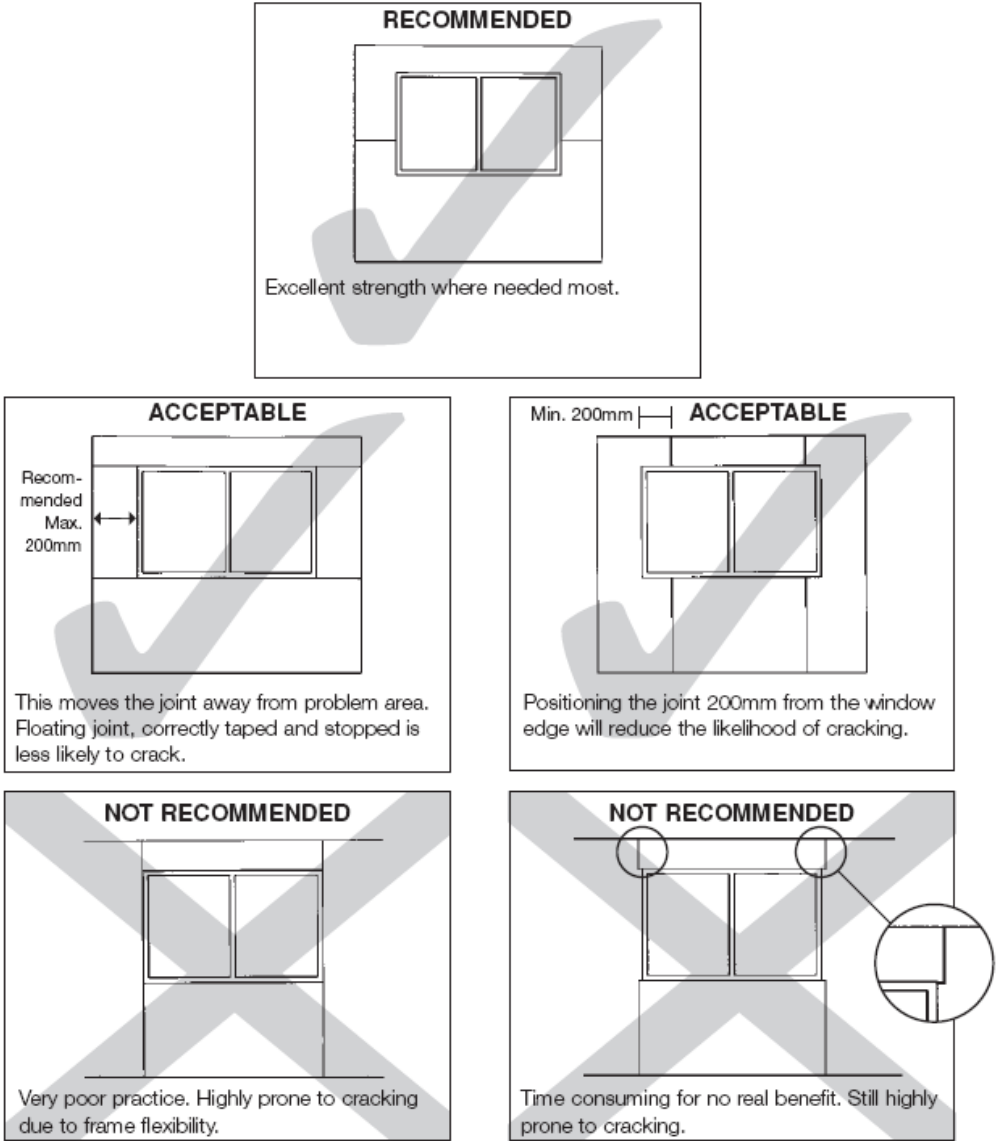

Control joints

Control joints relieve stresses imposed by structural movement including those due to excessive changes in temperature and humidity.

In long unbroken partitions or wall runs, control joints are required at 12 metre centres. They are also required where structural control joints occur in the primary structure and where USG Powerscape® interior linings meet dissimilar materials, except plasterboard of the same thickness. Door frames extending from floor to ceiling constitute an effective control joints.

Control joint should be backed by double framing spaced 12.5mm apart. Install control joints as per manufacturer's instructions. Suitable control joints include the USG Zinc Control Joint No.093 and the Rondo P35 control joint.

Ceilings

General Requirements

Framing dimensions must comply with the requirements of AS 1684.

- The use of steel battens is recommended to achieve a stable substrate.
- Because of the heat that can be generated in roof spaces, timber battens can be subjected to conditions that can cause substantial movement resulting in joint failure and popped fastenings. If the use of timber battens is unavoidable additional care must be taken to ensure that moisture content of the timber battens is in the 12-16% range. This will lessen the risk of defects. Note also that finger jointed battens can have different moisture contents in each of the individual pieces of timber that make up the batten. This could result in different rates of shrinkage in a single batten. Timber batten spans, spacing and dimensions as per AS 1684.
- Battens or ceiling joists shall be spaced as follows:-
 - 13mm USG Powerscape® interior linings - 600mm centres maximum.
 - 16mm USG Powerscape® interior linings - 600mm centres maximum.

All ceiling sheets must be fixed at right angles to the ceiling framing. Sheets must not be fixed in the same direction as the framing to which it is attached. All ceiling battens in a single area need to run in the same direction to enable this. Sometimes this will require sheet end to end joints. These joints should be tapered on site, and either back blocked or supported by a nog. Failure to do this will result in a tapered edge/cut edge joint at a point that is highly susceptible to cracking.

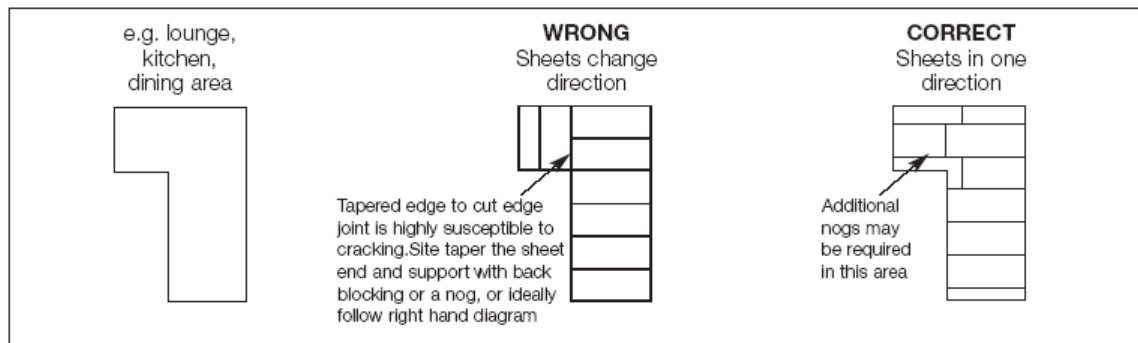

Radiant Ceiling Heating

Electric Radiant Ceiling Heating (ERCH) systems may give rise to abnormal localised or overall temperature conditions in ceiling spaces which could affect the timber framing and USG Powerscape® interior linings. Excessive thermal or hygrometric movement induced by these systems may result in some or combinations of the following defects; deterioration of the gypsum in the USG Powerscape® interior lining core (possibly affecting structural and fire resistant rating performance), fastener 'popping', joint peaking or joint cracking. Prior to construction, we suggest you contact your designer to fully consider these factors in order to optimise surface finish quality. USG Powerscape Pty Ltd will not accept liability for surface finish quality problems where ERCH systems are installed in conjunction with any USG Powerscape lining system.

Standard Fixing Details

Fastening and Jointing the Ceiling Lining

- Fasteners**
- Steel battens - 25mm x 6g self tapping screws, or high thread for light gauge. (for 13mm Fiberock lining)
 - Timber battens or Joists - 32mm x 6g high thread screws.
- Adhesives**
- Steel battens - Gypsum wallboard steel stud adhesive, follow manufacturer's instructions.
 - Timber battens - Gypsum wallboard timber stud adhesive, follow manufacturer's instructions.
- Fasteners Centres**
- Single screws to the edges and centre of the sheets across each batten.
 - Screws to be not less than 12mm from sheet edges.
 - 5 x Fasteners @ 300mm centres required across the 1200mm sheet width. Alternatively the 1/3 spacing can be used with a daub of Adhesive ie F-A-F-A-F per AS/NZS 2589 Table 4.4.3.2.5
 - Sheets ends at wall junctions are fully screwed at 200mm centres.
 - Do not place adhesive at sheet edges or under fasteners, this may lead to screw or nail pops.
- Lining**
- The lining shall be fixed at right angles to the battens or joists.
 - Commence fixing from the centre of the sheets outwards.
 - Sheets to be touch fitted.
 - Taper on site all non-factory tapered edges where sheets join before fixing.
 - Back-blocking of all joints not supported by the frame is required for level 4 and 5 finishes.
- Batten Spacing**
- 600mm centres max.

Fastening and Jointing the Ceiling Lining

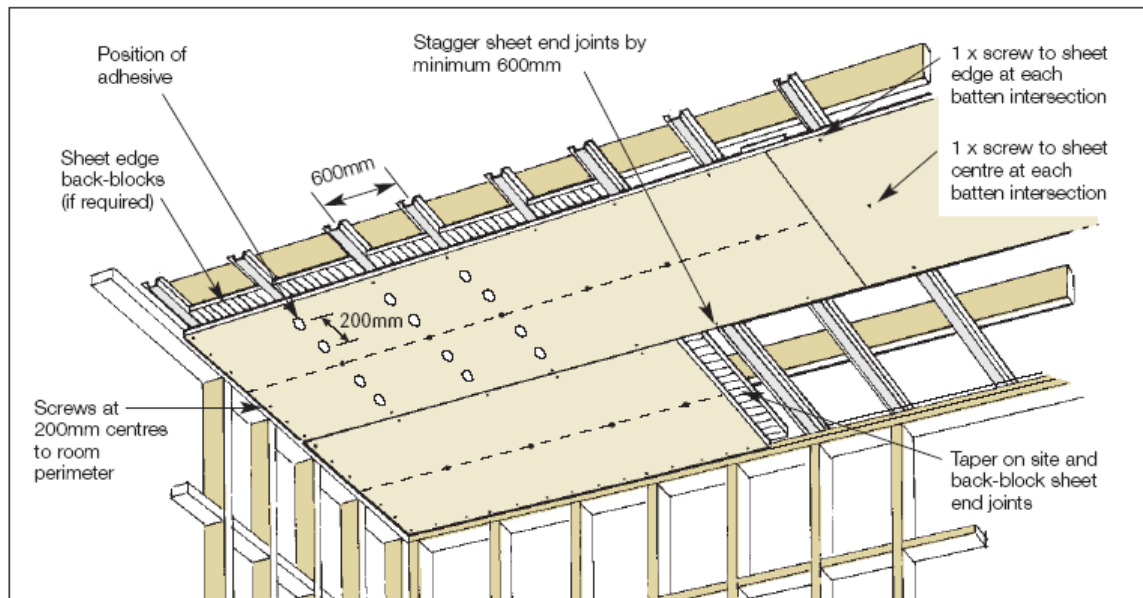

Ceiling batten system installation instructions

Consult an electrical contractor for any earthing requirement that may need to be incorporated.

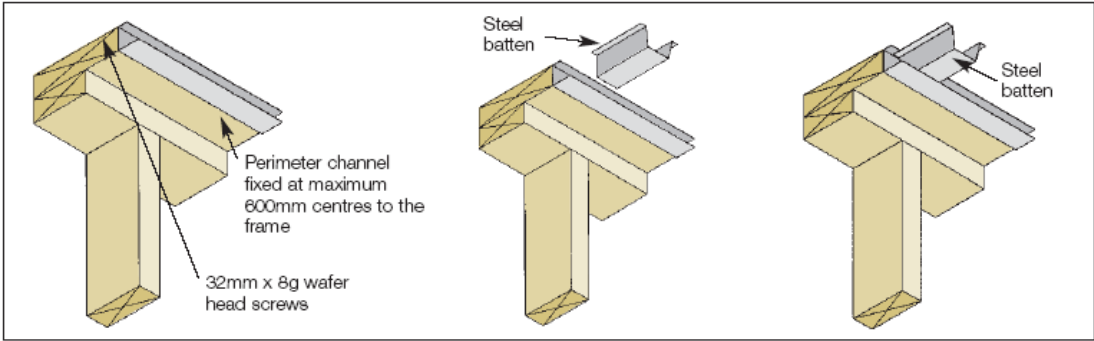

- Establish a datum line for the ceiling.
- Place a string line on the datum line at right angles to the battens, under the truss or joist closest to the centre of the room.
- Install clips at a maximum of 600mm centres using the string line to establish the correct position.
- Cut the batten to the required length using snips or a hacksaw.
- Insert the batten into the channel at each end and fit into the clip.
- Install remainder of clips ensuring that the batten is straight and flat.

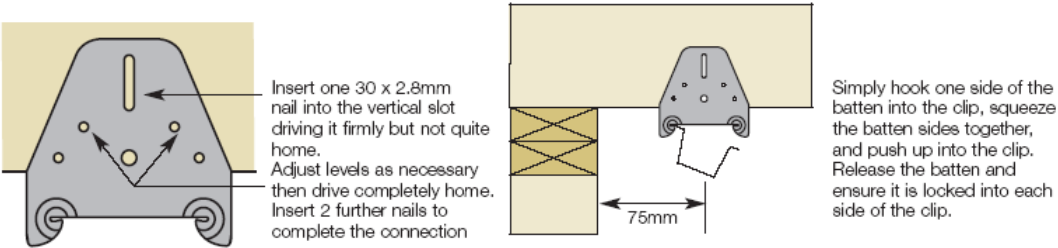
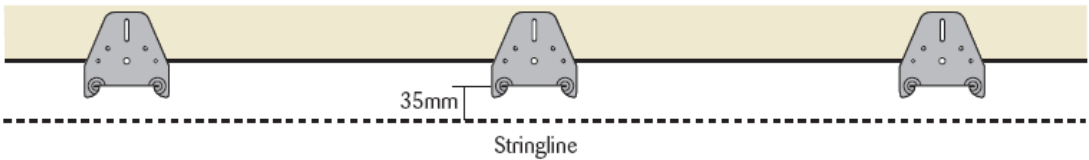

- If a joint needs to be made, use a batten joiner clip. It is not recommended to lap the joints as this can cause surface distortion.

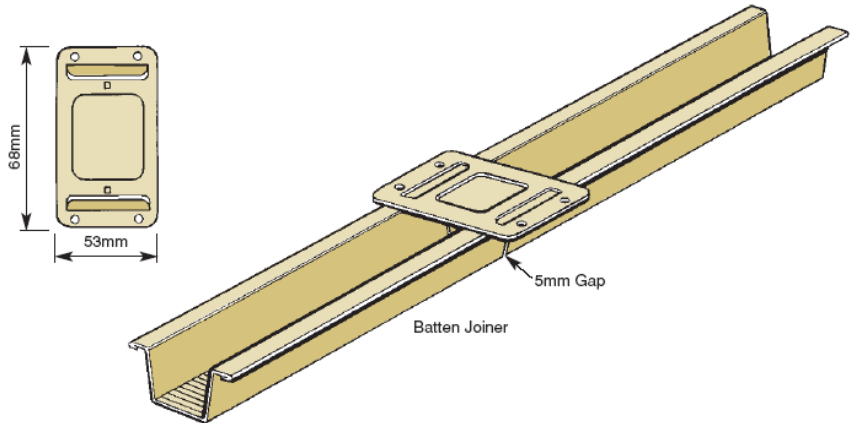

Back-Blocking

For general fixing, i.e. non fire rated systems, it is recommended not to fix sheet end butt joints on ceiling battens. Back blocking is the recommended option. Back blocking is a practice that strengthens and stabilises joints between USG Powerscape® interior lining sheets. Back blocking consists of laminating strips of interior lining to the back surface of the sheets directly behind joints using plasterboard chemical set compound adhesive. Panel, air-dry and cartridge adhesives are not suitable for back-blocking.

Sheet end and edge joints

Where sheet end joints are unavoidable, they must be placed centrally between framing members (battens or joists) and back-blocked. It is recommended that butt end joints be site tapered.

Tapered edge joints

To reduce the risk of cracks caused by substrate movement, USG Powerscape recommends back-blocking tapered edge joints in the following situations.

- When timber battens have been used: Any area containing 3 or more tapered joints. (Rooms 4.8m or wider)
- When steel battens have been used: Any area containing 6 or more tapered joints. (Rooms 8.4m or wider)

NB: When a level 5 finish has been specified for a ceiling ALL joints must be back-blocked, and all edge joints must be either factory or site tapered, and reinforced with paper tape.

Back Blocking Tapered Edge and End Joints in Ceilings (post lining installation)

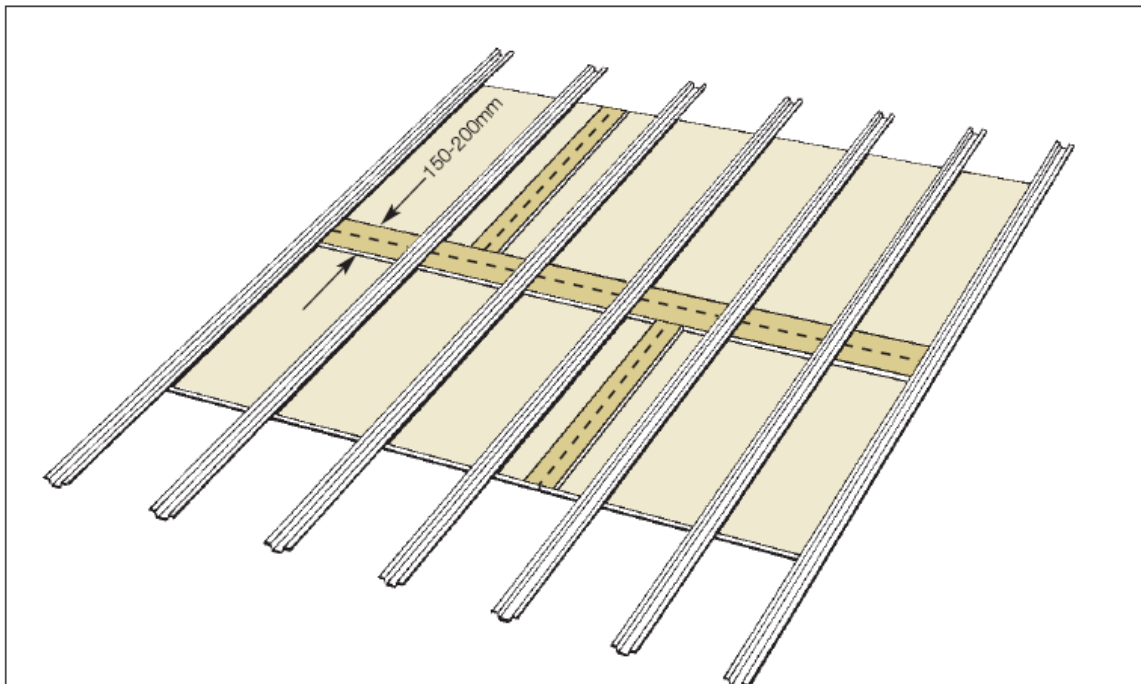

Skillion Roofs

Due to the high temperatures and low air flow that can occur in the confined space of a skillion roof, some special attention must be paid to detail in these areas. Ignoring these details can result in severe movement in the framing being transferred to the USG Powerscape® interior linings surface.

- Timber framing in skillion roof situations must comply with the requirements of AS 1684.
- Timber framing moisture content must be between 12-16% at the time of lining.
- No vapour barrier to be used between the back of USG Powerscape® interior lining and the underside of roofing material unless
 - The building is in a very cold environment (e.g. ski lodge).
 - Over a spa pool room or indoor swimming pool (USG Powerscape® interior linings are not generally suitable for this application).
 - Over a space in which wet industrial activity takes place (USG Powerscape® interior linings are not generally suitable for this application).

These applications require specific thermal design.

- Roofing underlay to be fitted as per roofing manufacturer's instructions.
- The roof cavity must be ventilated. A ratio of net free ventilating area to ceiling area should not be less than 1:150. e.g. Each 1 m² of ceiling area requires a venting area of 25 x 240 mm or 50 x 120 mm. Place in soffits, where possible.
- Space ventilation openings as evenly as possible to allow for the maximum airflow.
- Fix ceiling sheets at right angles to the battens.

Most membrane roofing manufacturers require ventilation of the roof space. These may exceed those required by Powerscape®. Refer to the relevant manufacturers instructions. Even if ventilation is not required by the membrane manufacturer the Powerscape® ventilation requirements must be met.

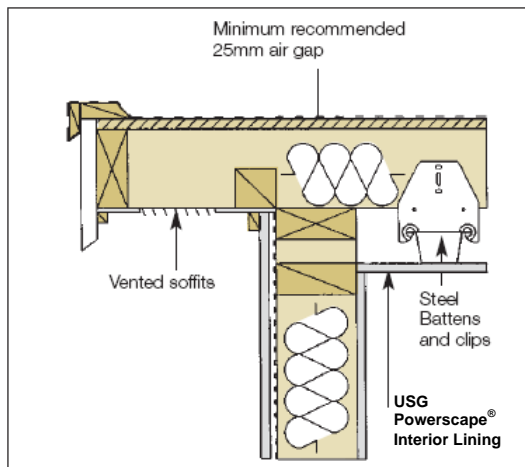
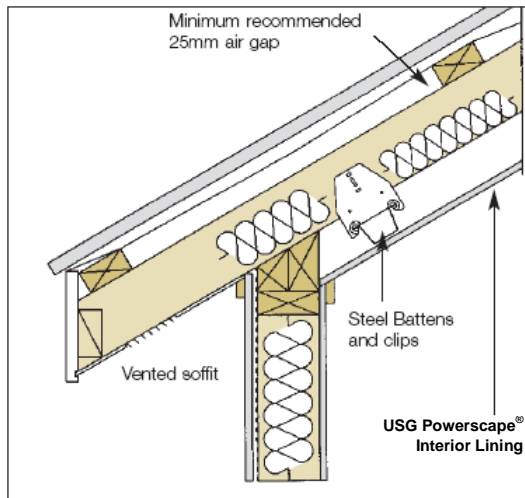
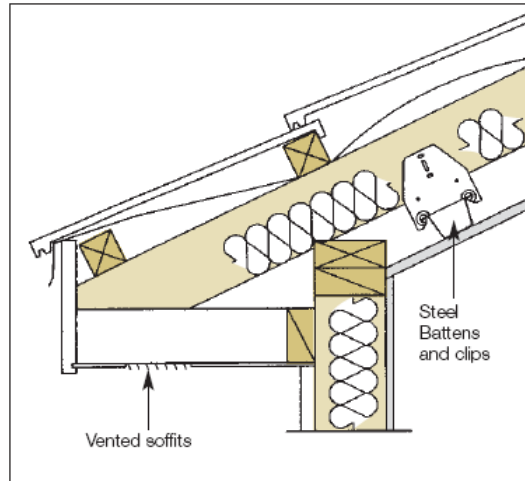

Paper Tape

The use of paper jointing tapes is recommended for use with USG Powerscape® interior linings. Paper jointing tape offers superior crack resistance as it absorbs compound to form a solid joint. Non-absorbent fibre mesh tapes are unable to do this and must not be used for jointing Fiberock. Paper tape comes pre-creased and has two distinct sides. The rougher side, facing out on the roll, is always bedded face down into the compound.

Joint Compound

The options for jointing compounds are numerous; however, these fall into two general categories.

1. The first is plaster based or setting compounds. They are supplied as a powder that is mixed with water immediately before application. They set to a hard finish as a result of a chemical reaction between plaster and water and are to be used for bedding in the tape.
2. The second are the pre-mixed ready-to-use compounds that harden by the evaporation of water. Generally these are softer and easier to sand and are normally used for the top coat. (Do not use with Powerscape Fiberock for taping as the base coat.)

For filling holes deeper than approximately 2mm or for slim angles setting compounds should be used. These may still be finished with the air-dry type compounds. The manufacturer's instructions must be adhered to when using any joint compound.

End joints and cut edges

For increased joint smoothness, the lining ends or cut edges may be bevelled or tapered to provide better contact with the joint compound and reduce possibilities of the finished joint protruding beyond the plane of the surface. Beveling or tapering can be undertaken using hand or powered planes (with dust extraction) or a Microplane® Fiberock® Rasp Blade – Model #30005. A hand rebate plane working wallboard to a scored line guide is particularly effective.



Tapered Edge Joints

Preparation

- Ensure that all fixings, screws or nails, are seated below the surface of the lining.
- Tidy up any damaged areas of the lining such as broken corners. It is usually easier to remove these completely and fill them with a plaster based (setting) compound prior to continuing.
- Remove any dust or loose material from the lining.
- Mixing instructions can be found on the back of the bag or pail. It is easier to mix a compound too thick than too thin as it is easier to mix in more water than more powder.

First Coat

1. Using a 150mm broad-knife, fill the taper formed by the edges of the sheets with setting type jointing compound.
2. Centre the paper tape along the joint and using a 150mm broad knife press the tape down into the compound.
3. Draw the broad-knife, held at approximately 45 degrees to the board surface, along the joint to remove any trapped air bubbles beneath the tape. Ensure that sufficient compound is left behind the tape to achieve a good bond.

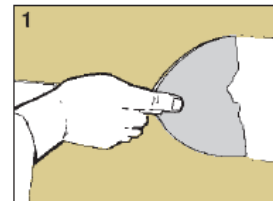

4. Immediately apply a thin coat of the same compound over the surface of the tape. This reduces the possibility of the tape curling and wrinkling which can lead to edge cracking.
5. When the compound is set (or dried) scrape back any build up of compound along the joint.

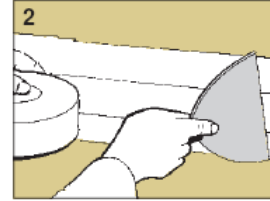

Second Coat

1. Apply a second coat of jointing compound with a 200mm trowel. Ensure that this coat extends outside the area of the first coat.
2. Feather the joints to eliminate build up of the compound at the edges.
3. Allow to thoroughly dry (24hours) and scrape back any build up of compound along the joint.

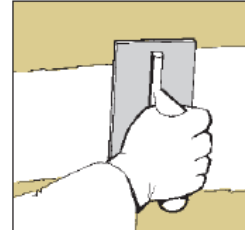

Top Coat

1. Apply a finishing coat of ready mix air-dry compound with a 280mm trowel. Joint edges should be feathered at least 50mm beyond the edges of the previous coat.
2. Allow to dry for approximately 24hours.
3. Lightly sand in the same direction as the joint using 220 grit, or finer, sandpaper.
4. After sanding, mark any defects and imperfections with a pencil, then retouch these areas with air-dry compound. Leave to dry and sand. Repeat this process until the desired finish is achieved.

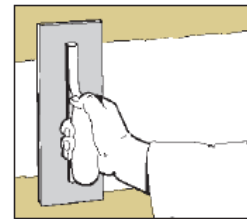

Non Tapered Joints

When jointing two cut edges or sheet ends, which are not tapered, care needs to be taken to ensure the surface build up of compound is minimised. The same basic procedure for tapered edge joints are to be followed except that the width of each stage is double that required for the tapered edge method. This procedure will result in a 600mm wide finished joint. Take extra care when bedding in the tape to ensure that sufficient compound remains behind the tape. The absence of a recess can often lead to all the compound being forced out from behind the tape. USG recommends forming tapers instead for greater joint strength and wall flatness.

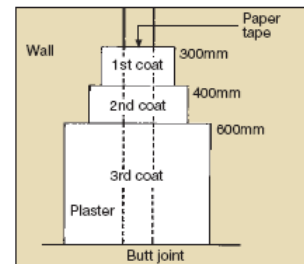

Screw, nail and staple spotting

The same process and compounds should be used as for stopping longitudinal joints when spotting screw holes.

1. Use a 100 mm broad-knife for each of the first two coats of compound.
2. Leave first two coats to dry for 24 hours prior to applying the finishing coat.
3. Use a 150 mm broad-knife for the finishing coat.
4. Leave to dry for 24 hours and then lightly sand with 220 grit sandpaper.

Dealing with Corners

Internal Corners

In most rooms there will be at least four internal corners where the walls meet. Internal corners are also formed at wall ceiling intersections. Often the wall-ceiling junctions are covered with Scotia, Cove or Cornice, however, these junctions can also be stopped using the same process. Setting type compounds should be used for deeper fills. These can then be finished with an air-dry compound. Delayed cracking can occur if air drying compounds are used at thicknesses greater than 1-2mm.

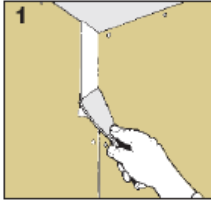

Fig. 1
Using a 75 mm chamfered broad knife apply the compound to both sides of the corner.

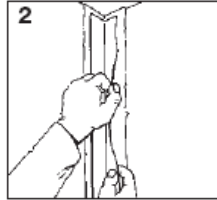

Fig. 2
Measure and cut the paper tape to length. Fold the tape along the centre line (crease) and bed the paper tape into the compound using the 75mm chamfered broad-knife.

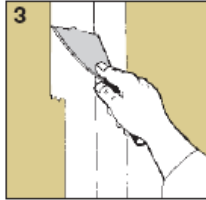

Fig. 3
Apply a thin coat of compound over the top.

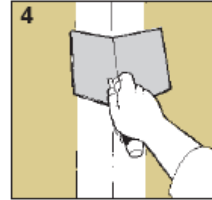

Fig. 4
Apply the final coat of compound, ensuring that the edges of the previous coat are completely covered.

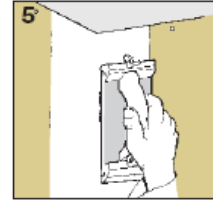

Fig. 5
Leave to dry and lightly sand with 220 grit sandpaper or finer. Sand in the direction of the joint being careful not to scuff the lining surface.

External Corners

External corners can be finished with metal trims or profiled paper faced plasterboard trims. Trims are available in a range of different profiles and are the preferred corner treatment as the likelihood of cracking occurring is reduced. Trims are attached over the corner and then covered with compound. Because of the thickness of plaster involved in covering these trims, pre-mixed compounds must not be used for the first two coats.

Repairing USG Powerscape® Interior Linings

Although the use of USG Powerscape® interior linings will eliminate the majority of crack and penetration impact damage, in some cases the wall may be subjected to severe force and damage may be sustained. Repair of such damage can be undertaken as for normal plasterboard.

Painting of USG Powerscape® Interior Linings

Surface Preparation

- Ensure all stopped surfaces are dry, sanded smooth and that any dust, oil grease or dirt have been removed with a soft brush, damp or dry cloth or a vacuum cleaner.
- Ensure that all windows, electrical fittings, furniture, covers, doors or other components not to be painted are masked out, covered or protected throughout the paint application process.

The following guidelines give a summary of best practices on painting plasterboard.

- Use flat paints rather than semi-gloss or gloss where possible. Gloss paints will reflect light to varying degrees, exaggerating surface imperfections.
- Light colours tend to diffuse light helping to disguise any surface imperfections. If it is intended that dark colours will be used then it is recommended that the services of an experienced tradesman be sought.
- Avoid the use of harsh lighting such as wall washers or creating situations that give harsh light such as windows extending to a wall or ceiling line. Where 'harsh' or 'critical' lighting conditions occur, i.e. where the dominant light source shines across the surface, imperfections will be easily seen. Consider skim coating the wall or applying a wallboard prep coat.
- Use water based paints, except in wet areas, as these will make it easy to create an 'orange peel' effect which helps to disguise any imperfections.
- 'Cut in' around edges and doors with a paint brush and then apply the remainder of the paint system using a medium to long nap roller (7-20mm). This will aid in creating a soft 'orange peel' effect.
- Always maintain a 'wet edge' with the roller and apply the last coat with the roller marks in the same directions and parallel to the dominant light source.

Paint systems should always be applied in accordance with the manufacturer's instructions.

Painting USG Powerscape® Interior Linings

	Wet Areas e.g. Bathrooms, ensuites, laundries	All other areas
Walls	1 coat alkyd primer 2 coats water based enamel	1 coat acrylic sealer Plus 2 coats acrylic paint
Ceilings	As for wet area walls	1 coat acrylic sealer Plus 2 coats acrylic paint

Paint Application

The choice of paint application tool in combination with the type of paint will significantly influence the ability of the paint to create an appearance of surface finish uniformity. The following comments are of a representative or general nature only as ALL paints must be applied strictly in accordance with the paint manufacturer's instructions.

Paint Type

Typically water based paints tend to have slightly more body and less flow out than oil based paints to support the creation of the mild orange peel effect with roller application.

Sealer Coats

Apply plasterboard sealers with a medium to long nap roller or brush. This improves their penetration and adhesion. If plasterboard sealers are to be applied by airless spray they should be back rolled immediately following spraying. If back rolling it is not undertaken, then differences in texture between stopping and board surface can telegraph through the paint layers. The exception to this is USG Sheetrock® Tuff-Hide® Level 5 Primer-Surfacer which is normally applied by airless spray and USG trained applicators. This must not be back rolled.

Finish or Top Coats

Both water and solvent based systems are available in a wide range of gloss levels. As a guide, gloss paints tend to have good clean ability and burnish resistance whereas matt or flat paints do not. Oil or solvent based paints are preferred in areas requiring a hard wearing surface or where steam, water resistance and clean ability are important.

Roller Application

Application of paints with a medium-long nap roller (7-20mm) will create a soft orange peel finish that aids in disguising surface defects. Use a smaller brush for “cutting in” around doors, windows etc or in difficult areas where the roller will not fit. Medium or long nap rollers hold larger quantities of paint and care needs to be taken not to over fill as this may result in drips or runs. Typically it is difficult to maintain a “wet edge” with water based paints during the summer or warm periods when applied onto large areas such as living room ceilings. Work into rather than away from wet edges so that any new charge of paint is spread towards the wet edge and a comparatively “dry” roller is used to make the “join”. The final “layoff” strokes in all sections must be in a common direction (which preferably should be parallel to the direction of the dominant lighting source).

Spray Application

When to paint in a large single area of interior linings spraying offers some benefits with water based paints. Once again use a smaller brush for “cutting in” around doors, windows etc or in difficult areas. Spraying creates a uniform film that will telegraph any underlying surface defects rather than disguising them. Back rolling immediately following spraying of finish coats is required for all applications where semi gloss or gloss paints are applied.

Fire-rated Wall Design Details

Track Fixing

Fix tracks to substrate with appropriate fasteners for the type of material being fixed to. Fix at 600mm centres maximum, no less than 20mm or greater than 100mm from ends. Fastener type and spacing may be dependent on other factors such as wind or impact loads. Always use the greater of the two.

Stud Fixing

Studs are to be installed at 600mm centres maximum, and are not to be mechanically fixed to the top or floor tracks. For heights up to 3.6M, allow a 15mm gap between the top of the stud and the inside of the top track to allow for thermal expansion under fire conditions.

Lining Fixing

Single layer linings to be fixed at centres on all studs as on page 4 table. Lining joints on opposite sides are to be offset from each other. Where two (or more) linings are required per side, these are to be offset also.

For two layer sides use 50mm x 8g drywall screws at 300mm centres or 50 x 2.8mm plasterboard nails at 200mm centres. Fastener types are minimums. Longer or slightly heavier gauge may be used where the above may not be readily available.

Adhesive fixing is not permitted – all fixings are to be mechanical fasteners of the type and spacing specified.

Allow a 5mm gap between the bottom of the Fiberock lining and the floor.

Lining Fire Rating

All gaps, joints, penetrations must be thoroughly sealed with an approved fire rated sealant, and intumescent collars where appropriate.

Lining joints are to use paper joint tape and chemical setting base coat and air dry finishing coats to the level of finish specified. To maintain a system Warranty it is recommended to use USG Sheetrock® paper tape with Sheetrock Durabond™ or Easy Sand™ setting compounds, followed by Sheetrock ready mix compound Total Lite™